

Smart
flexibility.

mlift

A to B effortlessly.
travel m — smartly taking you
where you need to get to, throughout
different levels, vertical or horizontal,
bridging destinations without having
to take a single step.

mlift thinks beyond the boundaries
of movement. Escalator and moving
walks for the enhancement of people's
mobility.

Product Presentation	05 - 09
Travel m	05
Handrails and balustrades	07
Steps, decks and floor covers	09
Product Information and Specifications	11 - 21
Product Overview - escalators	12
Arrangement Plan - escalators	13
Product Overview - moving walks	14
Arrangement Plan - moving walks	15
Standard Features	16-17
Optional Features	18-19
Materials, colors and surfaces	20-21
Technical Specifications	22 - 27
Escalators	22-23
Moving walks 1	24-25
Moving walks 2	26-27



travel m Durable outside, elegant in sight.

Travel m is the ideal conveying companion in both commercial or public environments. Indoor or semi-outdoor, it functions with intelligence and an adaptive flexibility providing superior user-friendly technology.

Our escalators and moving walks are built for durability and practicality. Assembled materials, elements and finishes are manufactured to the highest industry standards. Offering a variety of aesthetically appealing models in customizable dimensions, travel m conforms to varied environments and design needs.

Robust safety mechanisms, excellent energy efficiency, low decibel audibility and smooth operational maintenance are standard across all of our escalator and moving walk ranges. Smart integrated operating modes optimize low energy use, reducing overall running costs while ensuring a humble contribution for a greener planet.

All manufacturing and assembly processes of travel m systems are in rigorous compliance with the requirement standards of EN115-2017.



Graceful combinations Smooth feel, secure grip.

Travel m handrails are produced using strong factory-spliced closed loops with integrated nylon cord girding layer. This manufacturing process ensures a durable life expectancy for all our handrails, enduring daily wear and tear with great efficacy.

Personalize escalators and moving walks with three optional handrail colors to best suit your environment: jet black, charcoal grey or fire red.

Horizontally placed or vertically positioned, travel m handrails never shift from their base mounts, assuring passengers with grip security no matter the duration of the ride.

Balustrades crafted from slim profile safety panels seamlessly integrated with precise interlocking vertical joints, guaranteeing secure discreet finishing. Available in either clear glass, smoked glass or stainless steel.

Distinguish your travel m escalator or moving walk with LED railing or skirting illumination - adding extra luminescence, aesthetic appeal and visibility in low light situations.

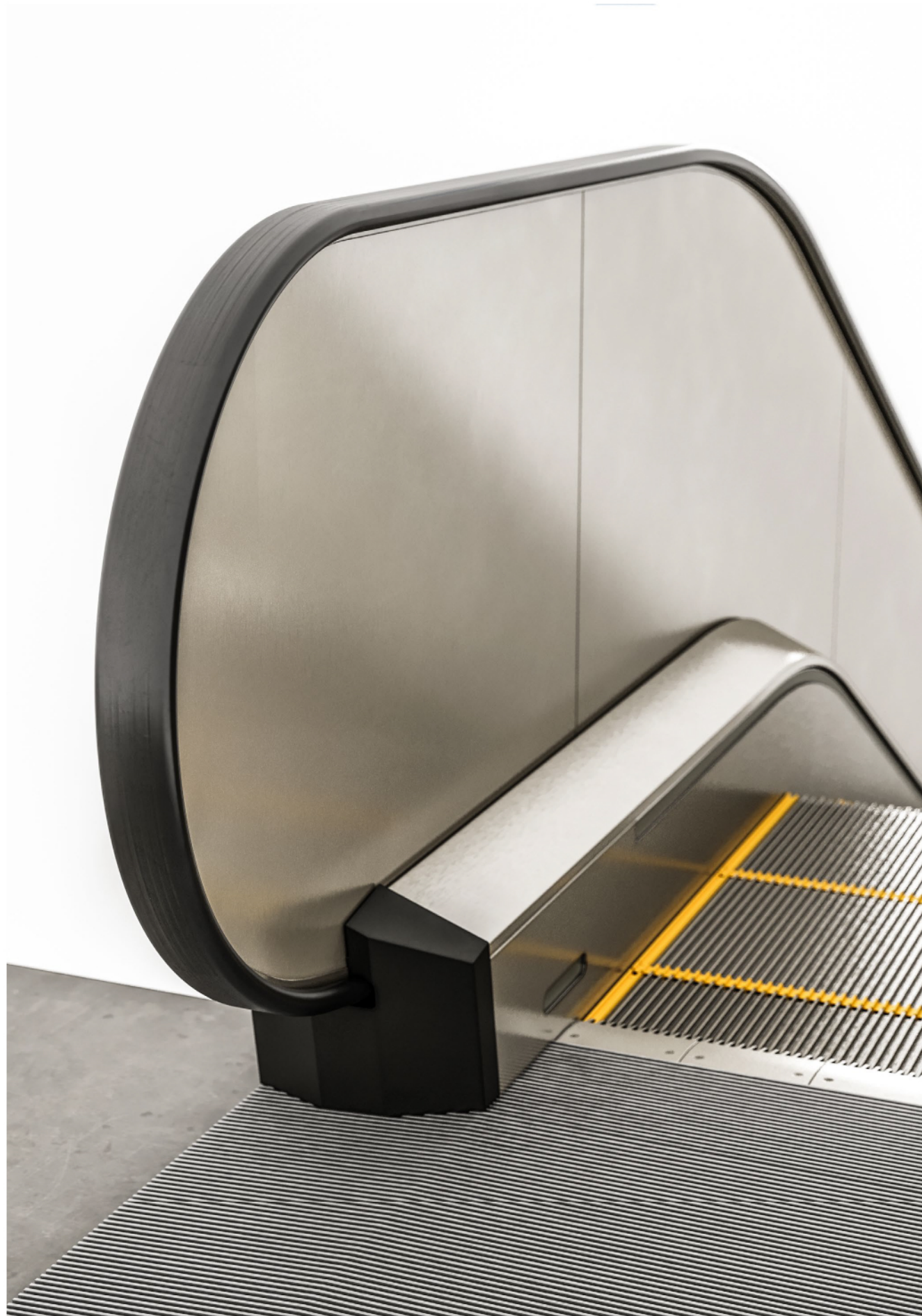

Step on - Step off Moving without walking.

Steps

Travel m steps are produced from die-cast aluminum and are scratch resistant. They are built with vertical anti-slip grooves as standard.

Our steps are synchronized and soundly integrated within the overall operational efficiency and safety mechanisms of our escalators. Minimizing overload, overheating and dropping to a lowest.

The steps are resilient, easily maintainable and virtually silent when running. Step demarcation in yellow synthetic resin for quicker visibility is optional.

Travel m decks, manufactured from plain stainless steel. They securely harness all components for mechanical, electrical, rail, and step systems. Their computer systems ensure continuous motion detection, stair activation, brake safety, and an operational panel for live feed monitoring.

Travel m floor covers add the finishing touch to the first or final step. An etched stainless steel panel clearly demarcates either the starting or ending point. All floor covers assure firm foot grip for steadier boarding and softer landing.

Product Information and Specifications

Detail	Description
Inclination	30° or 35°.
Rise and Inclination	Starting at 2 meters up to 6 meters: 35°. Starting at 2 meters up to 7.5 meters: 30°.
Step Width	600mm, 800mm or 1000mm.
Speed	0.5 m/s.
Power Supply	AC 3 phase. 5 wire 50Hz/60Hz.
Application	Indoor and Semi-Outdoor.
Balustrade Design	Slim profile safety tempered glass with a thickness of 10mm in either clear or smoke. Stainless steel with hairline finish. Balustrade height of 1000mm.
Handrails	Factory-spliced closed loops with nylon cord girding layer in Black, Grey or Red.
Handrail Entrance	Black plastic.
Deckings	Hairline stainless steel.
Skirting Panel	Hairline stainless steel.
Steps	Aluminium alloy die-cast steps in silver grey. With or without yellow synthetic resin demarcation.
Skirt Panels	Brushed stainless steel with integrated skirt brushes.
Lighting (optional)	LED skirt lighting in white. LED handrail lighting in white.
Floor & Combplate Covers	Engraved stainless steel without plain combfingers. Floor name engraved on stainless steel (optional).
Operating Panel	Red emergency stop button and up/down key switch.

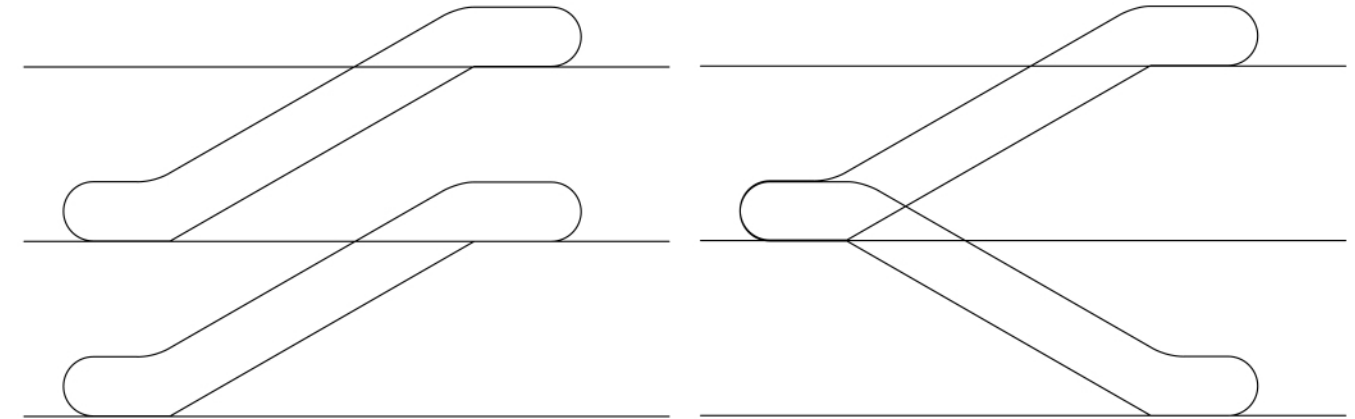

Parallel Interrupted Arrangement.

Interrupted Arrangement.

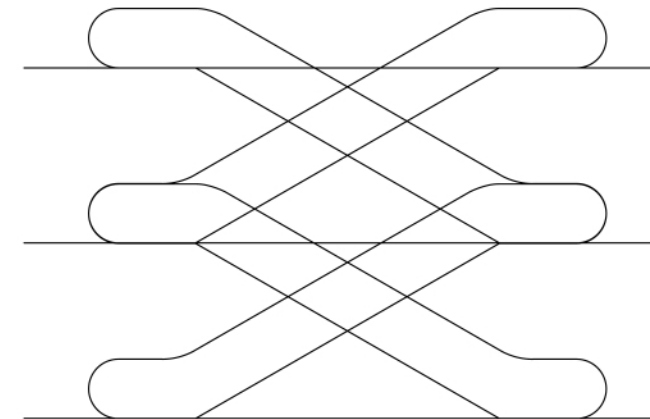

Crisscross Continuous Arrangement.

Product Overview - moving walks

Arrangement Plan

Planning

Detail	Description
Inclination	0°, 10°, 11° or 12°.
Rise and Inclination	Starting at 2 meters up to 7.5 meters: 10°, 11° or 12°. Starting at 20 meters up to 120 meters: 0°.
Step Width	800mm or 1000mm for inclinations of 10°, 11° or 12°. 1000mm, 1200mm or 1400mm for inclinations of 0°.
Speed	0.5 m/s.
Power Supply	AC 3 phase. 5 wire 50Hz/60Hz.
Application	Indoor and Semi-Outdoor.
Balustrade Design	Slim profile safety tempered glass with a thickness of 10mm in either clear or smoke. Stainless steel with hairline finish. Balustrade height of 1000mm.
Handrails	Factory-spliced closed loops with nylon cord girding layer in Black, Grey or Red.
Handrail Entrance	Black plastic.
Deckings	Hairline stainless steel.
Skirting Panel	Hairline stainless steel.
Steps	Aluminium alloy die-cast steps in silver grey. With or without yellow synthetic resin demarcation.
Skirt Panels	Brushed stainless steel with integrated skirt brushes.
Lighting (optional)	LED skirt lighting in white. LED handrail lighting in white.
Floor & Combplate Covers	Engraved stainless steel without plain combfingers. Floor name engraved on stainless steel (optional).
Operating Panel	Red emergency stop button and up/down key switch.

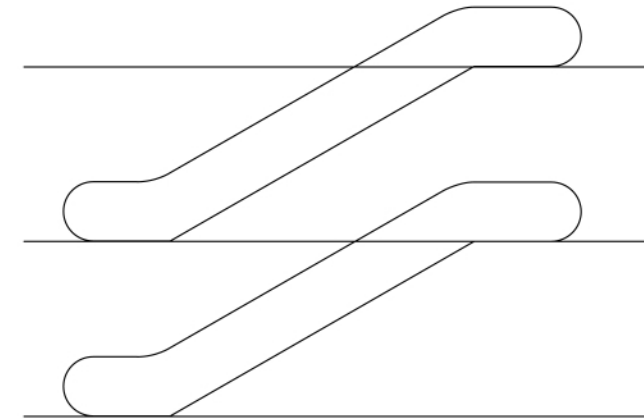

Parallel Interrupted Arrangement.

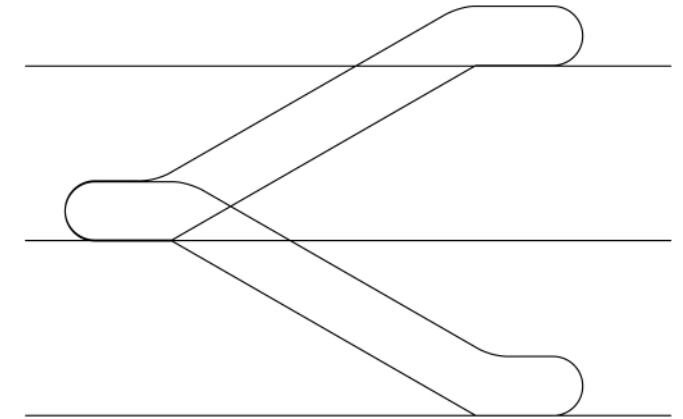

Interrupted Arrangement.

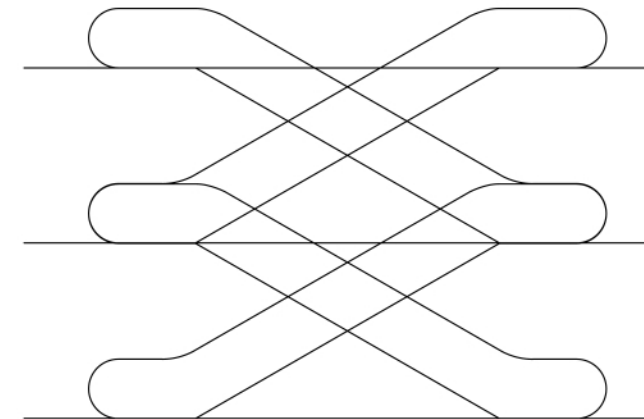

Crisscross Continuous Arrangement.



Parallel Interrupted Arrangement.

Standard Features	Description
Emergency Stop Button	A button that immediately stops the escalator in emergency situations.
Start Key Switch	A tri-state self-reset switch meant to start the escalator.
Handrail Safety Guard	A safety device that stops the escalator when physical contact or blockage is detected between the handrail and the inlet.
Step Chain Safety Device	A safety device that stops the escalator if the Step Chain breaks or stretches beyond an acceptable limit.
Step Level Safety Device	A safety device that stops the escalator if the horizontal level of the step has dropped and if the step can no longer mesh with the comb plate.
Phase Monitor	The phase monitor stops the escalator immediately in the case of any phase dislocation or phase loss of the input power supply.
Zinc Steel Flying Wheel Cover	The zinc steel flying wheel cover protects the motor's flying wheel from any potential damage during maintenance service.
Overload Detection Device	A safety device that stops the escalator if overload is detected either by abnormal current or drive motor temperature change.
Overheat Detection Device	A safety device that stops the escalator if motor overheating is detected.
Comb-Step Safety Device	A safety device that stops the escalator if a foreign object becomes stuck in the gap between the Step and the Comb.
Maintenance Interlock Switch	A maintenance switch that restricts the Start Key Switch of the escalator from being activated when the inspection handle is operated.
Buzzer	A warning system located on the outer decks warning passengers that the escalator is about to start.
Missing Step Safety Device	A safety device that immediately stops the escalator if any step is missing.
Anti-Static Handrail Roller	A roller that removes any potential static electricity from the moving handrails.
Anti-Static Step Brush	A brush that removes any potential static electricity from the steps of the escalator.
Brake Safety Device	A safety device that stops the escalator if it detects that the service brake is not breaking properly or failing to break at all.
Soft Stop Device	A device that reduces the speed of the escalator before braking is activated in order to prolong the life-span of the brakes hence reducing service visits.

Standard Features	Description
Handrail Speed Safety Device	A safety device that stops the escalator in case the handrails are running at an unusual speed or if they fail to synchronize with the Steps due to slippage, loosening or breaking of the Moving Handrails.
Power Box Switch	Used to activate or deactivate the escalator. Situated in the top machine room.
Landing Plate Switch	A switch that auto-activates to stop the escalator when detecting that the landing plate (maintenance cover) is removed.
LCD Operation Panel	An LCD screen that displays the operational state of the escalator as well as possible faults or shortcomings.
Step Upthrust Device (Escalators Only)	A safety device that stops the escalator in case an object gets trapped between two steps dislocating the step. Also prevents the steps from dropping.
Speed Governor Device	A safety device that stops the escalator should the speed increase to 120% of the rated speed or beyond. This device will also cut down the power supply to the main drive motor and the brakes in case accidental reversal is detected.
Auto Lube System	A device that keeps the drive, steps and handrail drive chains well oiled and lubricated. This feature is a standard, yet it is mandatory for outdoor applications.
Circuit-Breaker Safety Device	A device that stops the escalator in case any short-circuit or earth leakage is detected in the electrical circuit.
Fire Stop Device	A device that stops the escalator when a signal of fire-fighting action is received. The fire signal supplied by the building's fire system should be NC, dry (passive) contact.

Optional Features	Description
Electromagnetic Brake	A safety device that stops the escalator in the case of power failure, or if any safety device or Emergency Stop Button gets activated. This feature is mandatory for escalators extending beyond six meters.
Drive Chain Safety Device	A safety device that stops the escalator if the Drive Chain breaks or stretches beyond an acceptable limit.
Remote Monitoring	A system that monitors the status of the escalator with computers through four dry contacts. Available for Building Management Systems.
LED Traffic Indicators	Indicates to passengers the operational direction of the escalator, stop, no entry or other situations .
LED Comb Illumination	LED illumination in white located on both sides of the Comb Plates.
Step Gap Illumination	LED illumination in green under the Combs located at the top and bottom ends of the escalator.
Handrail Illumination	LED illumination in white located at the lower edges of the handrails.
Machine Room Illumination	Fixed lighting for top and bottom machine rooms.
Skirting Illumination	LED dot type or LED with diffuser type illumination on the Skirting Panels on both sides of the escalator.
Skirt Guard Safety Device	A safety device to stop the escalator in case a shoe or any other object gets stuck in the gap between the Step and the Skirt.
Zinc Steel Drive Chain Cover	The zinc steel cover protects the Drive Chain from any potential damage. This feature is mandatory for outdoor applications.
Handrail Safety Device	A safety device that stops the escalator in case the handrail damage is detected such as slippage, loosening or breaking.
Machine Room Steps	A set of steps located inside the top and bottom machine rooms for easier access during maintenance service.
Special Cable Requirement	Fire retardant or low smoke and halogen-free fire retardant.
Anti-Climb Device	A device that blocks passengers from climbing into the escalator from the sides.
Outside Cladding	Plain stainless steel with hairline finish - thickness of 1mm. Painted steel in a variety of RAL colors - thickness of 1mm.

Optional Features	Description
Cable Protection	Metal or plastic raceway protecting cables from heat, humidity, corrosion and other environmental threats. This feature is mandatory for outdoor applications.
Skirting Brush	A single row of standard brushes with aluminium brackets located on both sides of the Skirts. This feature is mandatory under EN115 requirements.
Comb Heating	Mandatory for outdoor or semi-outdoor applications where the ambient temperature is below 4°C and in cases where machine rooms are located in outdoor environments. The heater is situated inside the upper and lower truss, right under the comb plate with an output of 1.5Kw.
Truss and Comb Heating	Mandatory for outdoor or semi-outdoor applications where the ambient temperature is below 0°C. The heater is situated inside the truss with an output of 1.5Kw.
Oil-Water Separation Device	A device that separates oil from water inside the machine rooms.
Float Switch Device	A safety device that stops the escalator in case the water level inside the bottom machine room rises beyond the acceptable level. This feature is mandatory for outdoor applications.
Passenger Detection Device	A 3D sensor device located at the handrail entrance. Y-Δ stops the escalator in case no passengers are detected and makes it start again as soon as a passenger approaches to enter the escalator. VVVF stops the escalator in case no passengers are detected and makes it start again as soon as a passenger approaches to enter the escalator. In case no passengers are detected for some time, the escalator will run at a slower speed and eventually come to a stop if no passengers are detected in sight.
VF Energy Saving Device	A photocell sensor that makes the escalator run at low speed if no passengers are detected and then automatically accelerate back to its normal speed as soon as a passenger approaches to enter the escalator. In case no further passengers are detected, the escalator will run back at low speed.

Steps

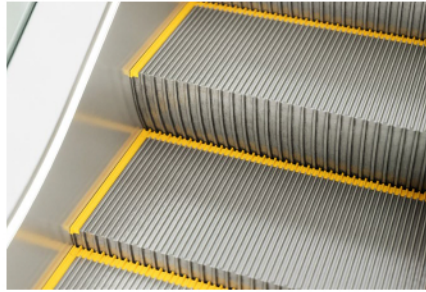

Aluminium alloy steps in silver grey coating.

Demarcation Line

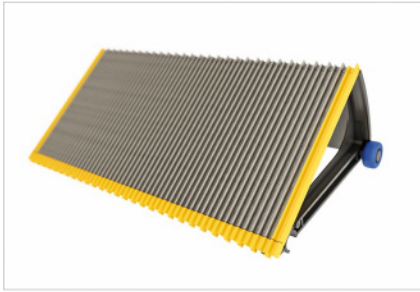

Synthetic resin in yellow.

Landing Plate

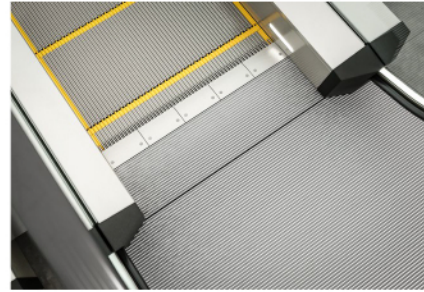

Etched stainless steel.

Complate

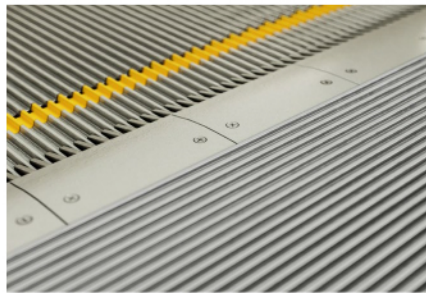

Silver grey coating.

Decks



Stainless steel in hairline finish.

Skirting

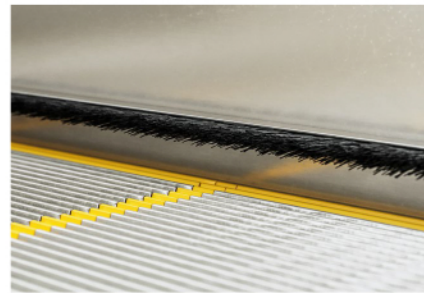

Stainless steel with integrated black brush.

Handrail Entrance



Black plastic.

Indicators

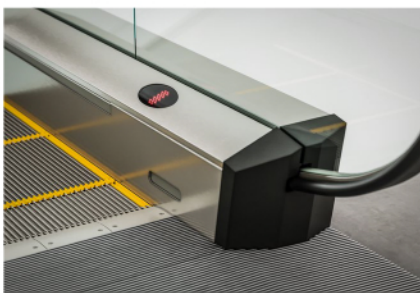

Landing area no-entry sign in red LED.



Traveling direction entry sign in green LED.

Illumination



Handrail illumination in white LED.



Skirting illumination in white LED.

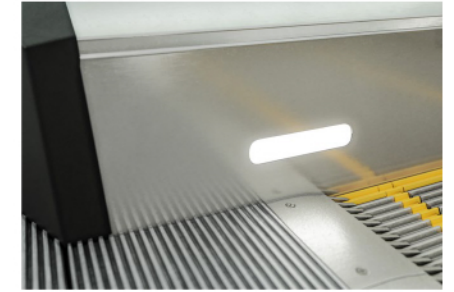

Comb illumination in white LED.

Moving Handrails



Jet Black.



Charcoal Grey.



Fire Red.

Balustrade

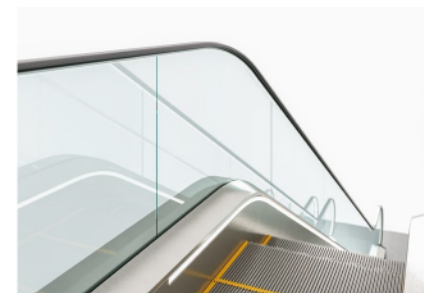

Slim profile safety tempered glass - clear.

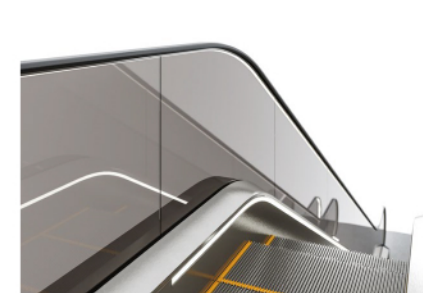

Slim profile safety tempered glass - smoke.

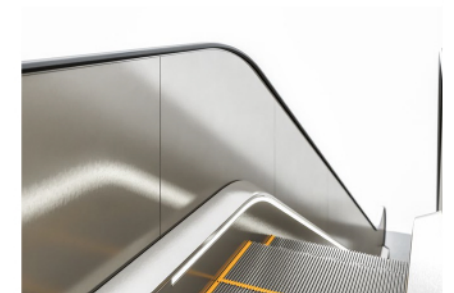

Slim profile stainless steel - hairline finish.

Layout plan

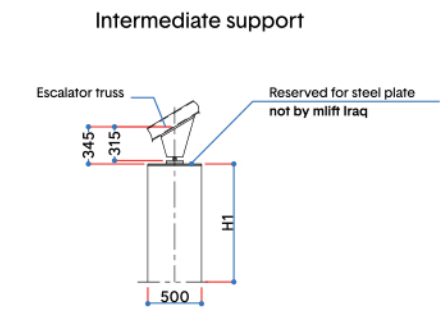
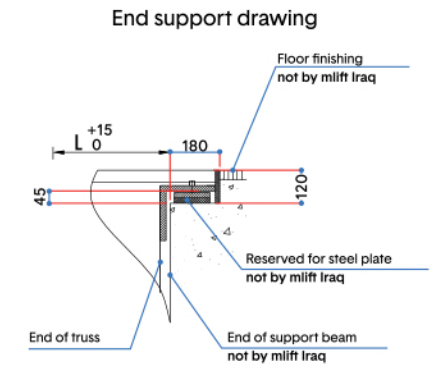
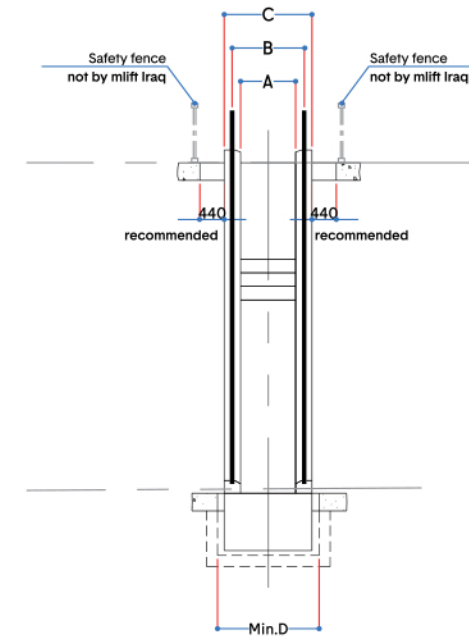
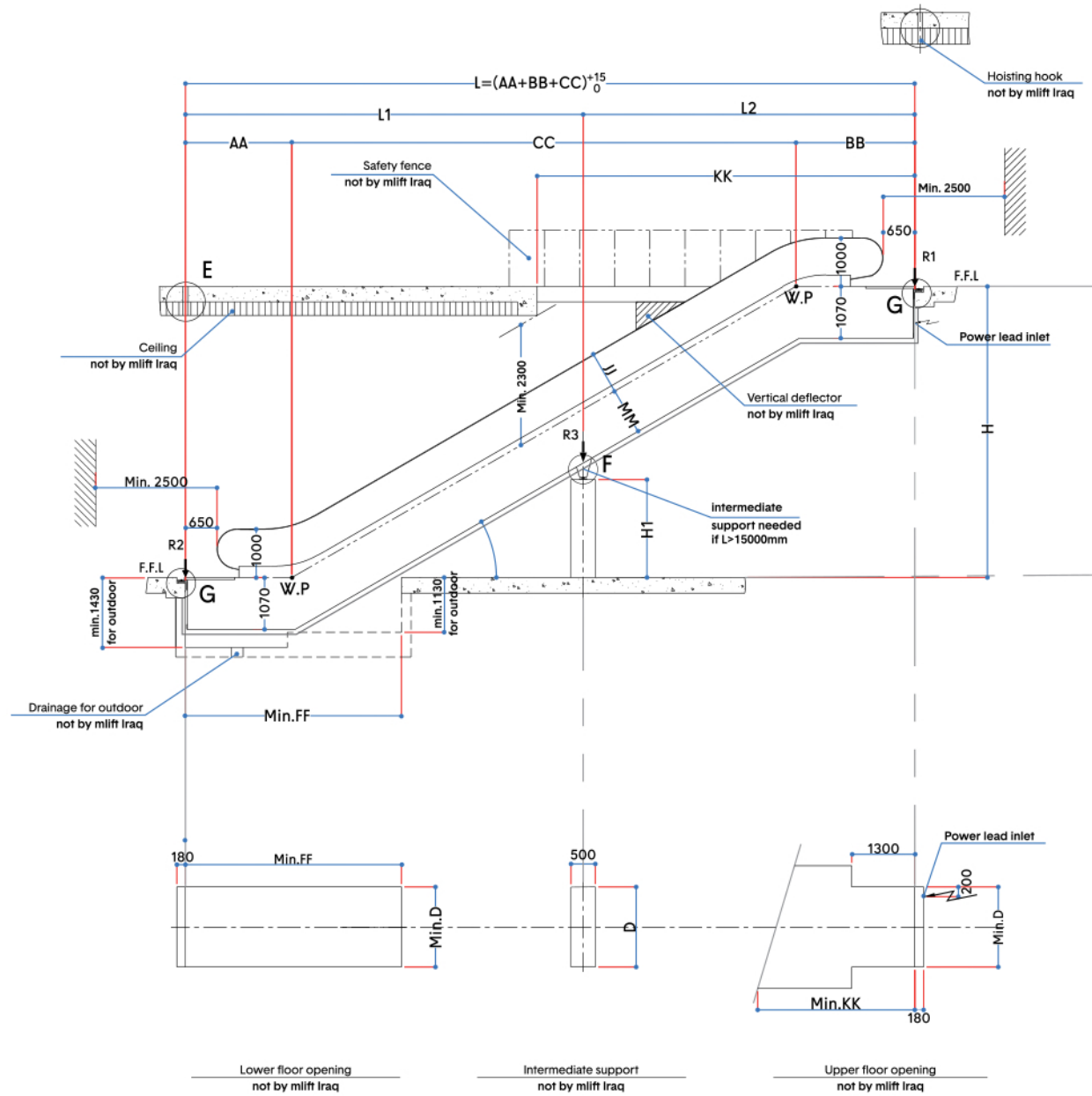

Technical specifications

All dimensions are in mm. Please note that dimensions are subject to change.

Step Width	600	800	1000
A: Step width	600	800	1000
B: Width between handrails	837	1037	1237
C: Handrail center distance	1145	1345	1545
D: Width of escalator	1200	1400	1600

Horizontal Steps	a	AA	BB	CC	DD	FF	JJ	KK	MM
2 steps	30°	2195	2449	H x 1.732	2238	4200	870	7800	960
2 steps	35°	2229	2510	H x 1.428	2386	4000	850	7000	980
3 steps	30°	2595	2964	H x 1.732	2638	4600	870	8300	960

Transport Capacity - persons/hour	4500	6750	9000
A: Step width	600	800	1000

Layout plan

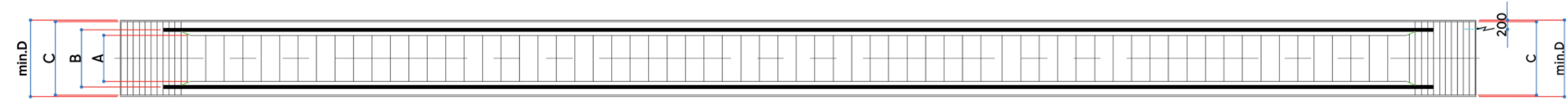
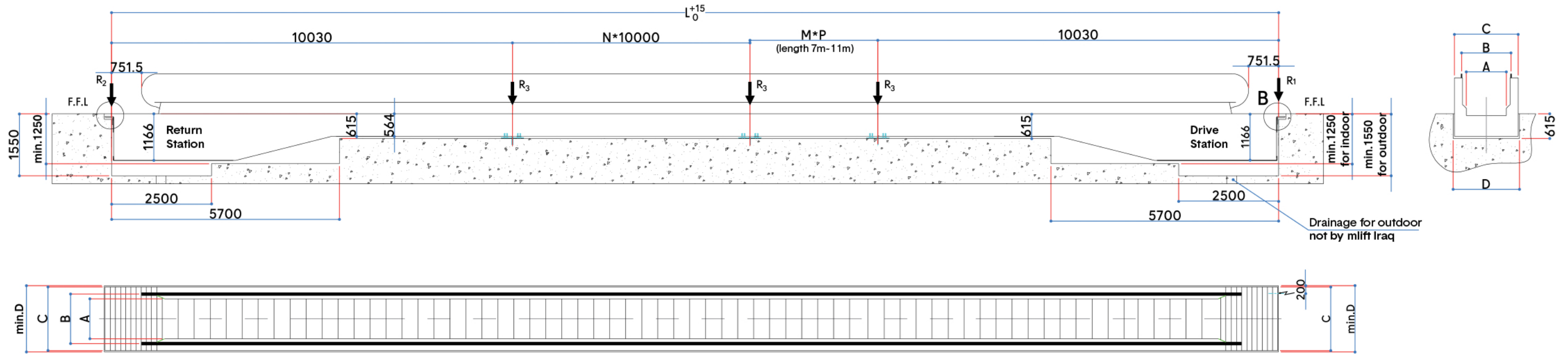

Technical specifications

All dimensions are in mm. Please note that dimensions are subject to change.

Step Width	1000	1200	1400
A: Step width	1000	1200	1400
B: Width between handrails	1237	1437	1637
C: Handrail center distance	1595	1795	1995
D: Width of escalator	1670	1870	2070
Transport Capacity at 0° - persons/hour	6000	6000	6000
A: Step width	1000	1200	1400

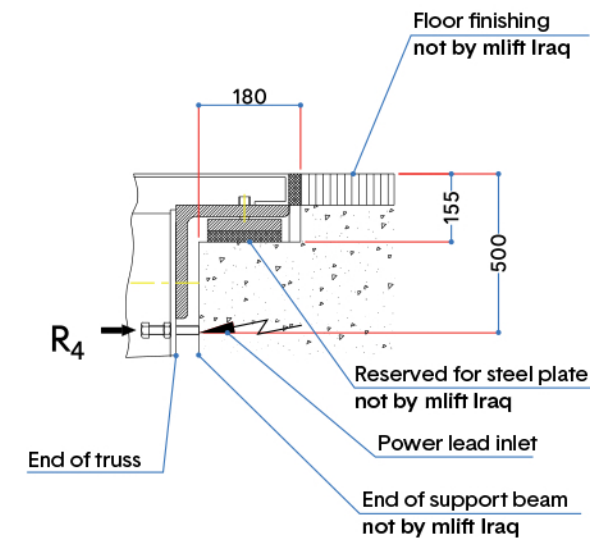

A horizontal exploration of vertical living.

